

Wt_Action

Sequential structure
Action Step Logic

Conditional structure
Action GetPut or
Others Logic

Custom Logic

Action_Get Example

Action_Mov Example

Action_Put Example

Wt_Action_Get() - Example

Here's an example of the Action_Get process.

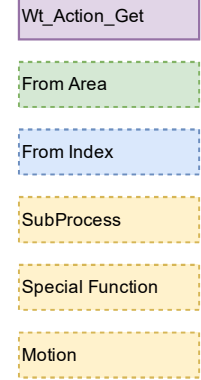
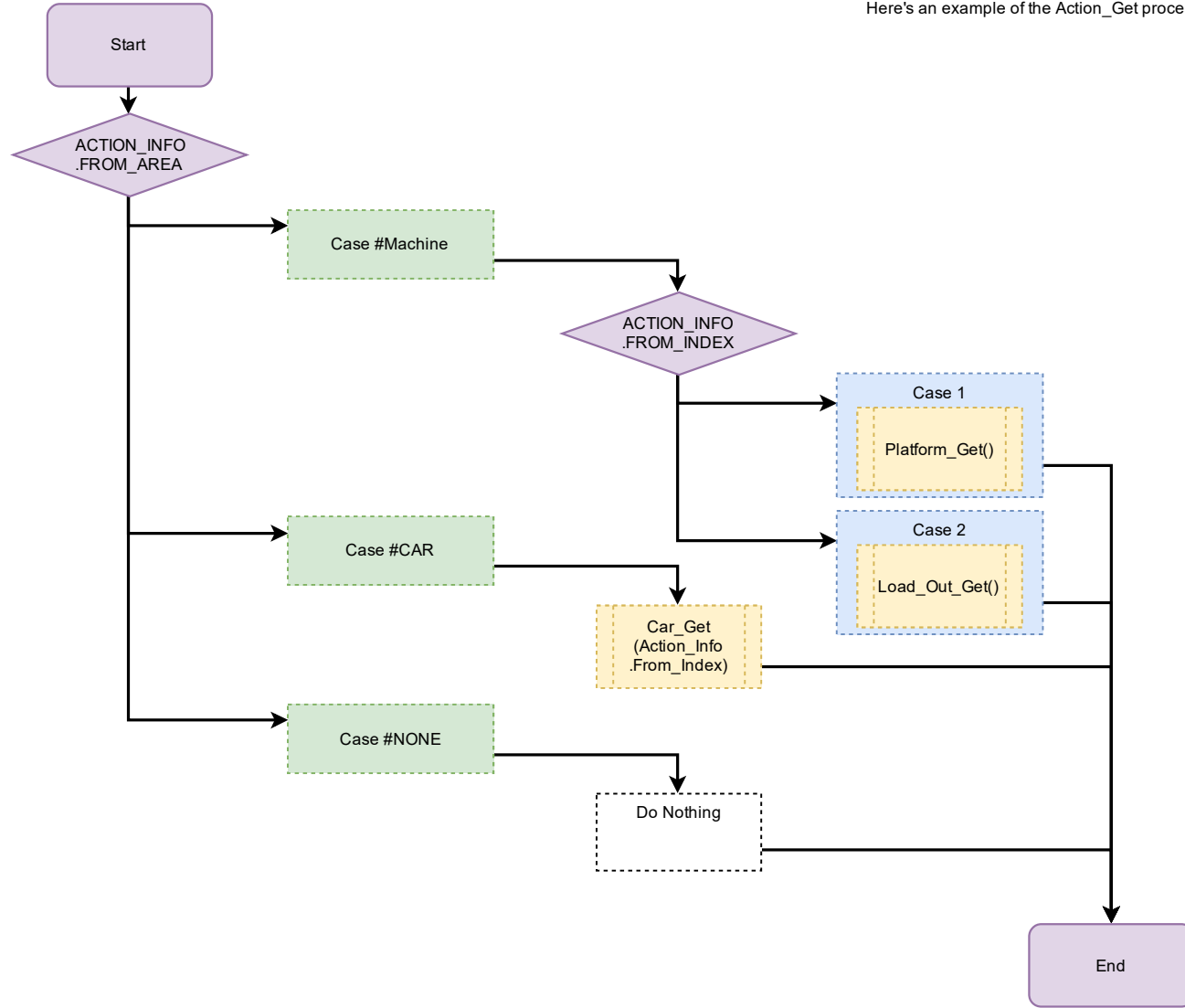

Wt_Action_Put() - Example

Here's an example of the Action_Mov process.

Wt_Action_Mov

From Area

To Area

SubProcess

Special Function

Motion

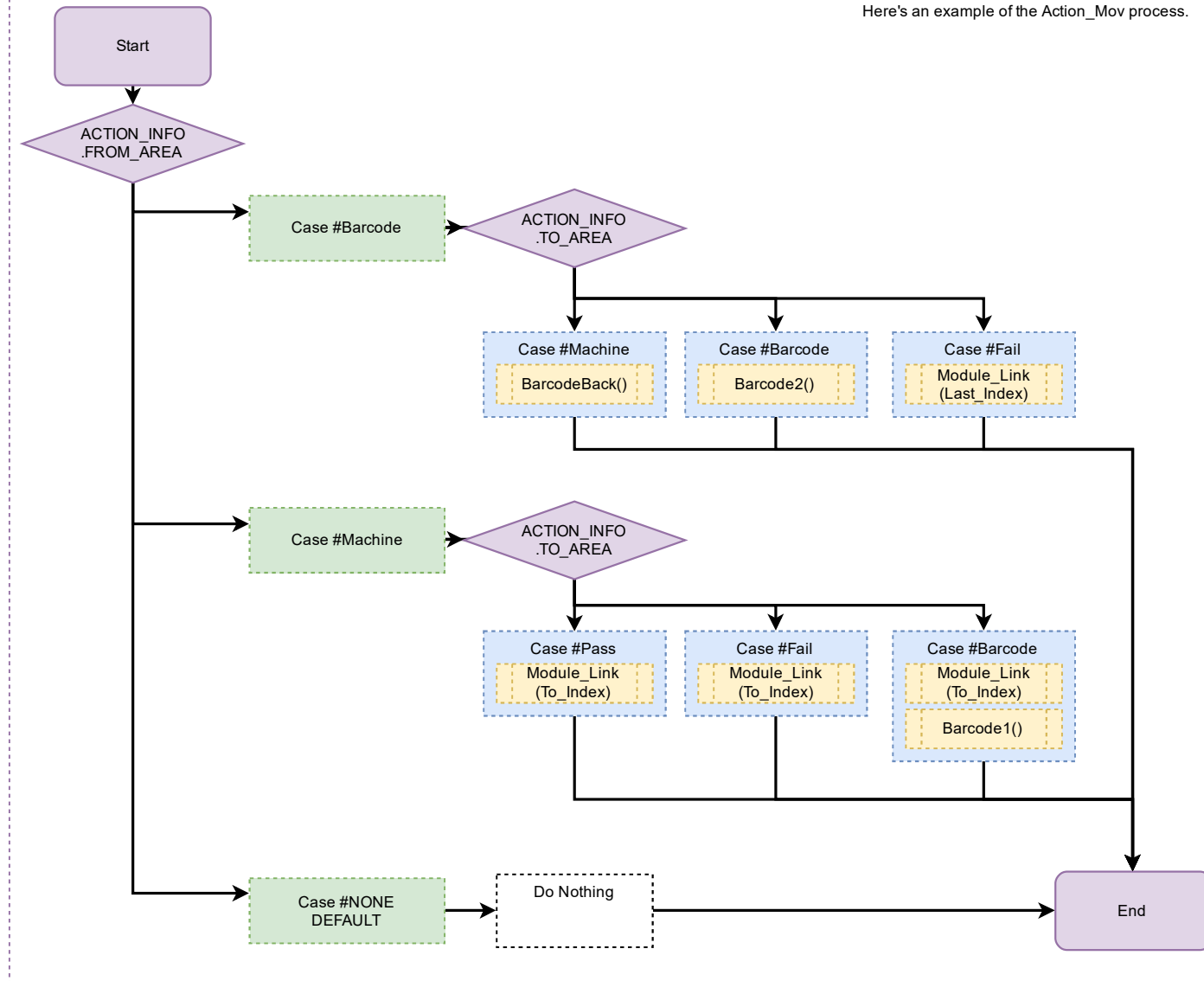

Wt_Action_Put() - Example

Here's an example of the Action_Put process.

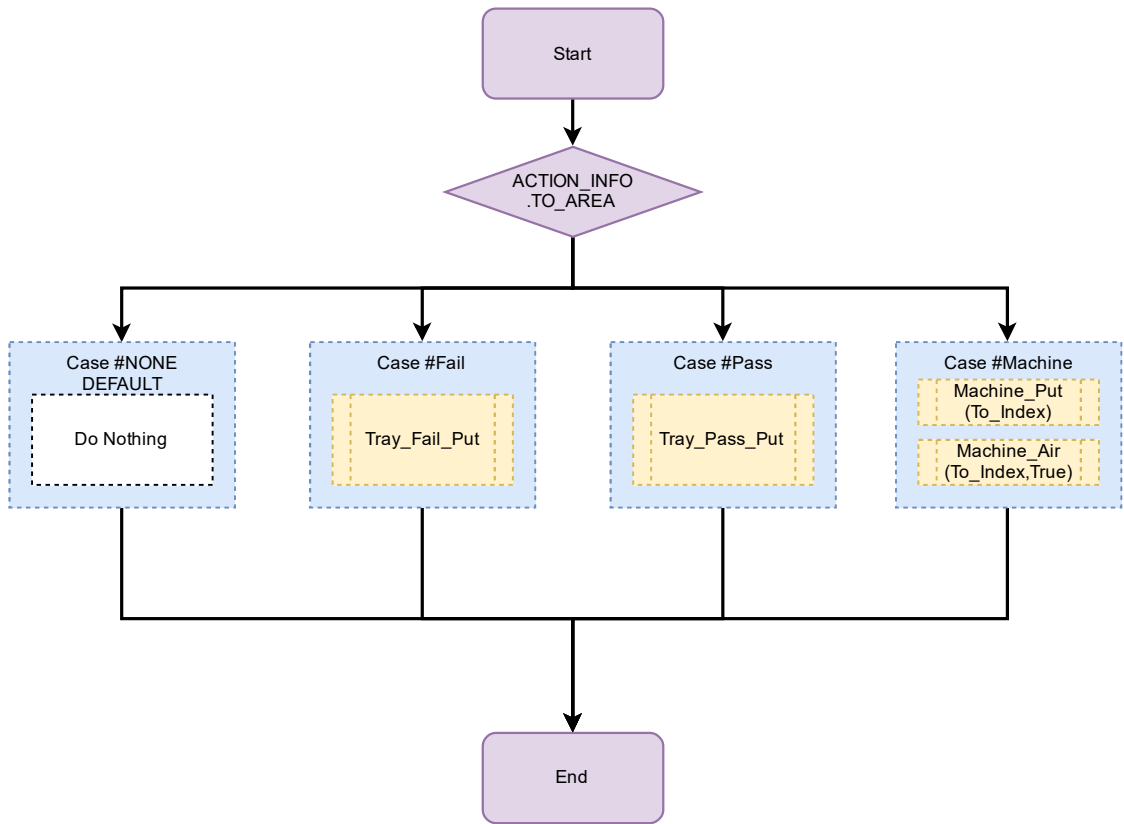

Wt_Action_Mov

To Area

SubProcess

Special Function

Motion

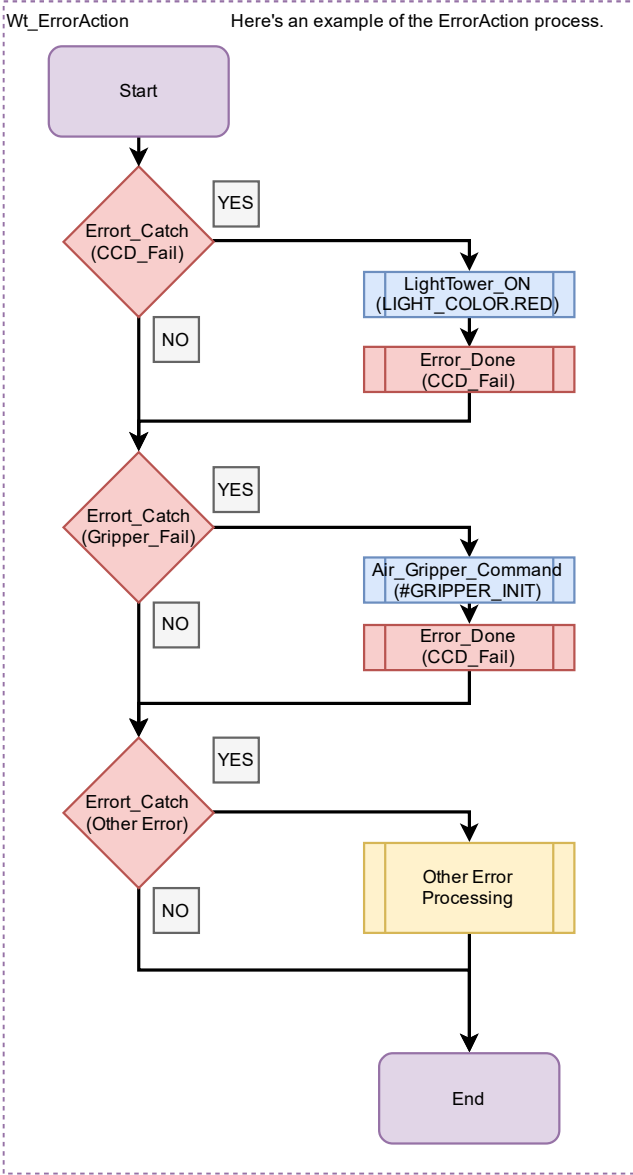
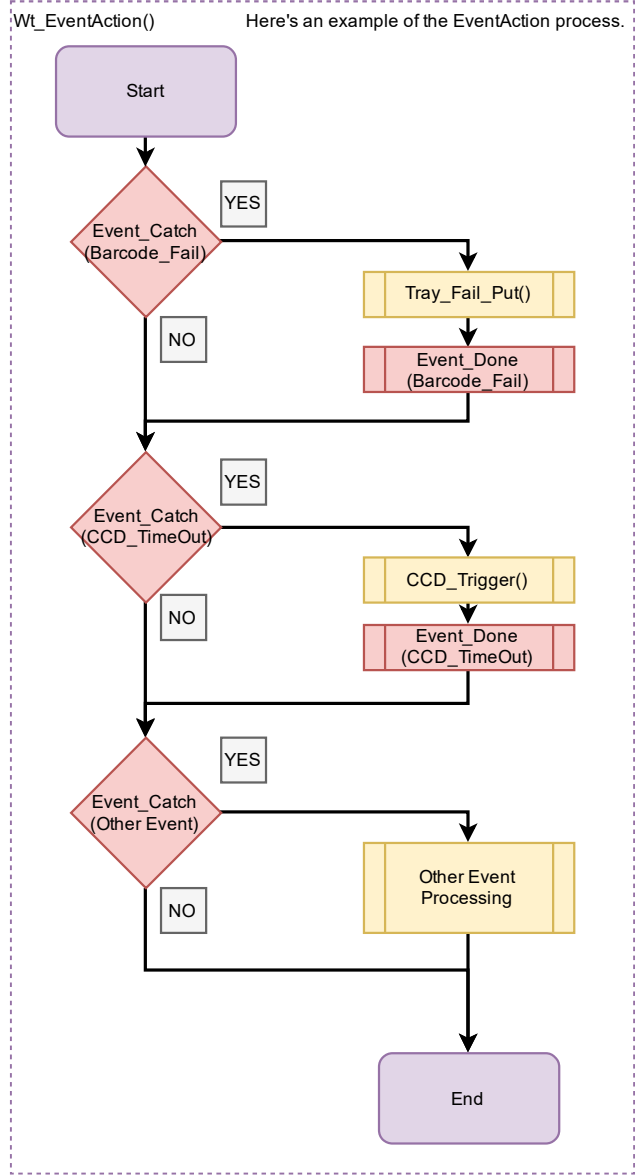

- Wt_EventAction
- Wt_ErrorAction
- Wt_Excrtion
- Wt_LightTower
- Wt_Air_Gripper
- SubProcess
- Special Function
- Motion